

SSL Resource

Goniophotometer Catalogue 2026/1

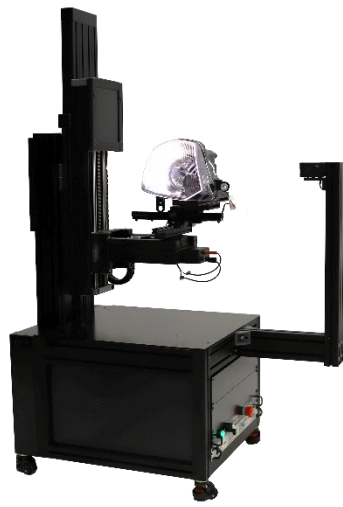



Content

- ❑ Goniophotometer types..... 3
- ❑ SSL goniophotometer features..... 4
- ❑ C-type goniophotometer - Software features..... 5
- ❑ B/A type Goniophotometer - Software Features.....7
- ❑ Measurement ranges..... 11
- ❑ Goniophotometer Laboratory Setup..... 13
- ❑ Type C Goniophotometers..... 19
- ❑ SSL LUMI series..... 20
- ❑ SSL DECO 27..... 24
- ❑ SSL LAMP 30..... 26
- ❑ SSL LEDI 70.....26
- ❑ SSL LAMP 200..... 27
- ❑ SSL UNI 170..... 27
- ❑ SSL C-1 series datasheet..... 28
- ❑ Type B/A Goniophotometers..... 29
- ❑ SSL AUTO 100..... 30
- ❑ SSL AUTO 140..... 31
- ❑ B type Goniophotometers – datasheet..... 32
- ❑ SSL AUTO 50.A33
- ❑ SSL AUTO 500..... 34
- ❑ SSL AUTO 1000.....35
- ❑ Goniometer System Delivery..... 36
- ❑ Ordering information..... 37

Goniophotometer types

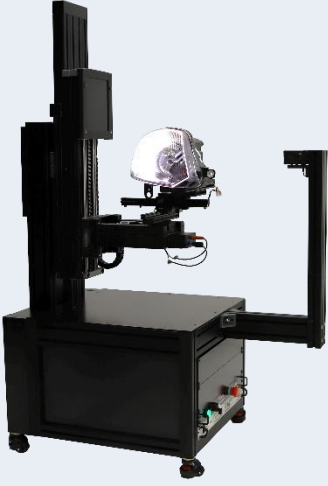
Summary table of different types of goniophotometers

Goniometer type	Type A	Type B	Type C
Fixed axis (angle name)	Horizontal axis: (Vertical α angle)	Vertical axis: (Horizontal β angle)	Vertical axis: (Vertical γ angle)
Moving axis (angle name)	Vertical axis: (Horizontal "A plane" angle)	Horizontal axis: (Vertical "B plane" angle)	Horizontal axis: (Horizontal "C plane" angle)
Example application	Automotive, Airfield lighting Maritime	Auxiliary car lights, Railway lights	General lighting Street lights
Example product			

SSL GONIOPHOTOMETER FEATURES

ALL INCLUSIVE MEASUREMENT SYSTEM

- ✓ Accurate characterization of spatial photometric, colorimetric and spectrometric features of luminaires by C / B / A type goniophotometer
- ✓ Luminous flux and efficacy
- ✓ Input power and power factor
- ✓ Spatial color uniformity (SDCM)
- ✓ Total correlated color temperature (CCT), color rendering index (CRI) and spectral radiant flux distribution
- ✓ Luminance camera based UGR measurements according to CIE 232



SSL SH Lin-2, 2-handed sample holder for super fast sample mounting.

(photo: SSL LUMI 180)



SSL SH Lin-3, 2-handed sample holder for super fast sample mounting.

(photo: SSL LUMI 90)

SAVE TIME, SPACE AND MONEY

- ✓ Fast sample mounting by a 2-handed sample holder and remote control
- ✓ Automatic luminous area measurements and turning axis adjustment
- ✓ Reliable LDT/IES measurements in standard height rooms
- ✓ User-friendly and versatile test software
- ✓ Sample holders, installation and training service, etc.
- ✓ Fast colorimetric measurements

C Type Goniophotometer - Luminous intensity Parameters

- ✓ File converter (e.g. IES>LDT)
 - ✓ IES, LDT, TM-33 XML file output
 - ✓ LDT editor
 - ✓ Up & Down combination tool
 - ✓ Beam symmetrization tool
- Wide range of spatial illumination related analysis parameters, some examples below:

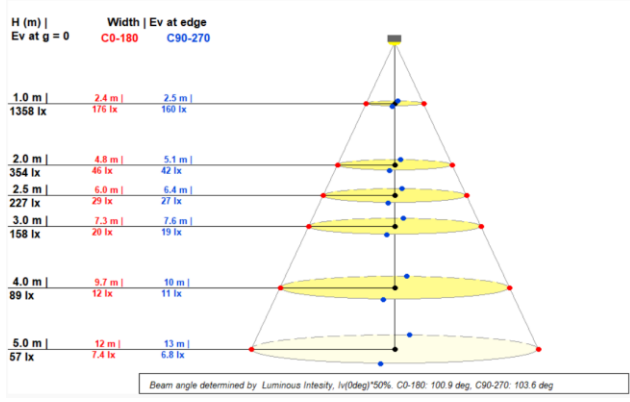
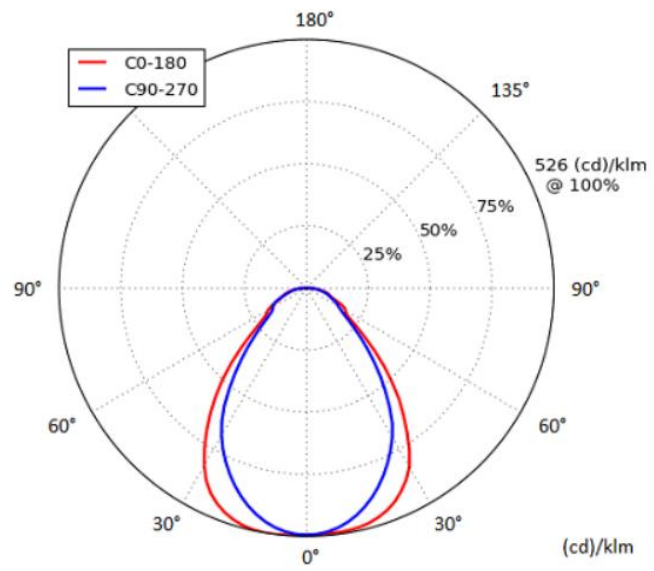

Fig. Dynamic cone diagram.

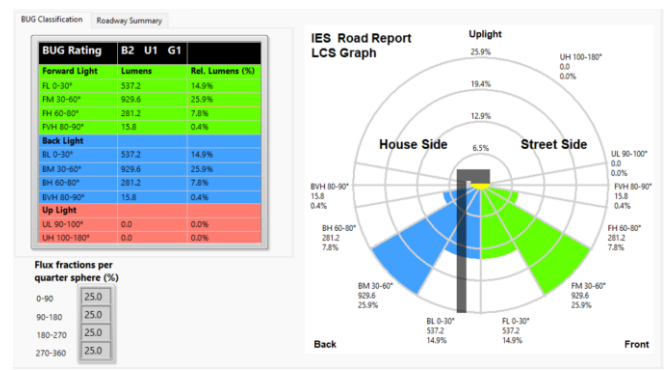

Fig. BUG (back, up, glare) diagram.

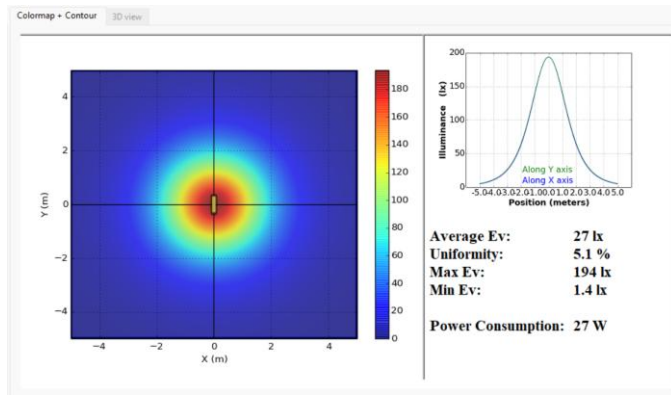

Fig. Spatial Illumination tool. Units: $\mu\text{mol/s/m}^2$, mW/m^2 and lx. Distances, nr of lamps etc. can be changed.

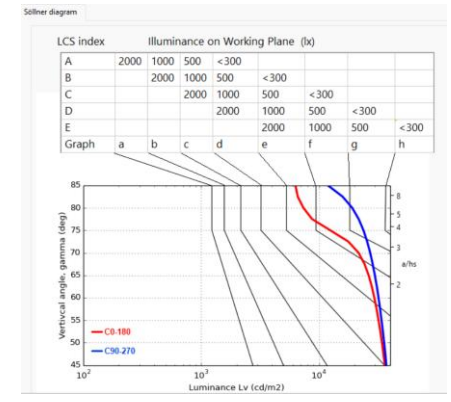

Fig. Söllner diagram for luminance.

C Type Goniophotometer - Color Measurement Features

- ❑ Total integrated values:
 - ✓ CCT, CRI, TM30-18
 - ✓ CIE1976, CIE1931
 - ✓ WL Bandwidth analysator
 - ✓ Optical power
 - ❑ Angular dependent values:
 - ✓ CIE 1976, CCT, CRI-Ra
 - ✓ Peak WL, Bandwidth
 - ✓ Relative/absolute spectrum
 - ✓ Radiant intensity distribution (LDT/IES files in units of mW/sr or $\mu\text{mol/s/sr}$)
- Wide range of analysis parameters available, some examples are shown here:

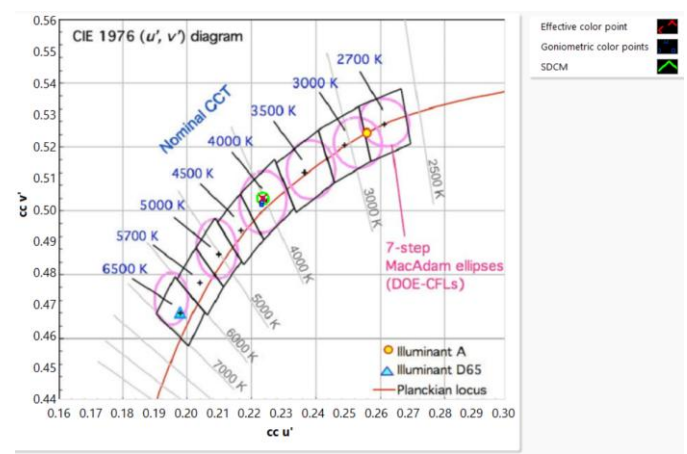
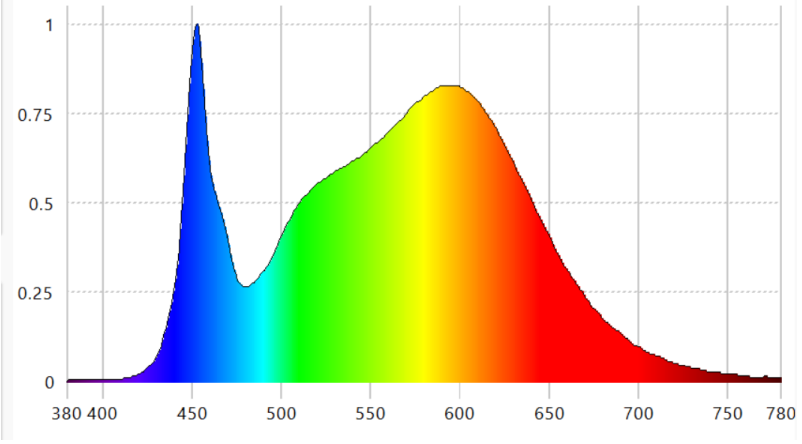

Fig. Spatial color uniformity (SDCM).

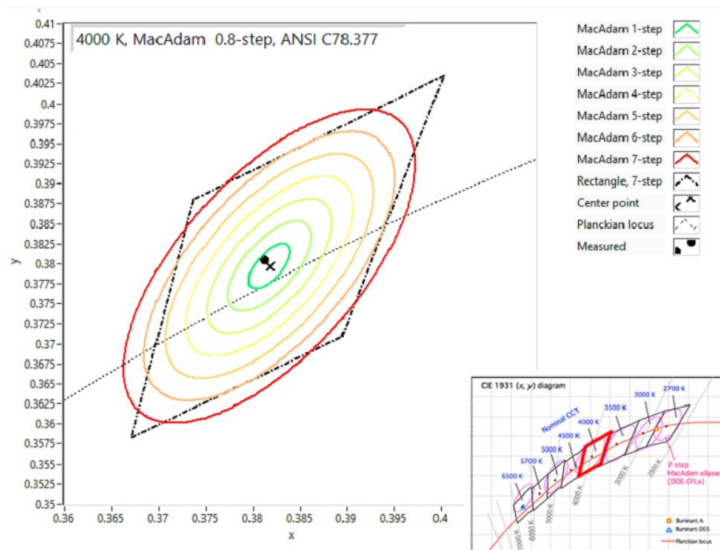

Fig. Color class SDCM value of target color point.

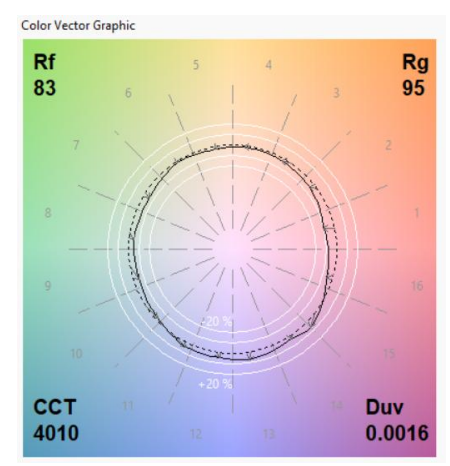

Fig. Color vector figure of TM-30-18 color rendering metrics,

A/B Type Goniophotometer - Software Features

- ✓ PASS / FAIL Test according to the different standards such as ICAO, CAP437, ECE, FVMSS108, FAA..
 - Candela tool for Elevation and Azimuth angles
 - Candela tool for Horizontal and Vertical angles
 - Editor of Candela Test Specification
- ✓ Analysis tool for Road surface illumination and at transversal plane
- ✓ Isolux analysator

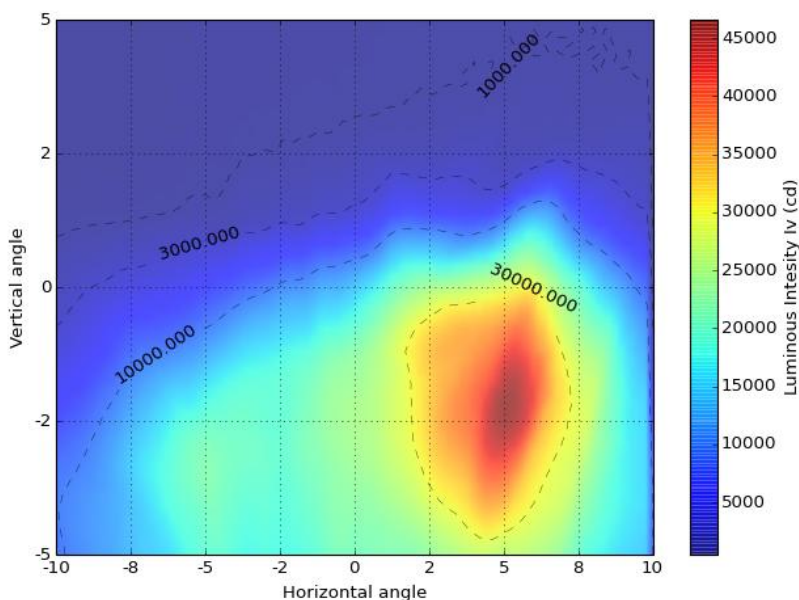

Fig. 2D luminous intensity beam –presentation.

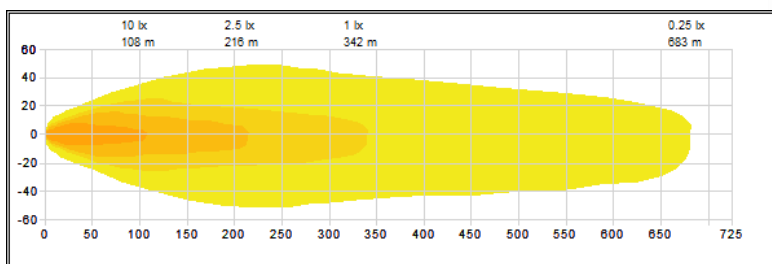

Fig. Simulation of horizontal isolux of auxiliary car light.

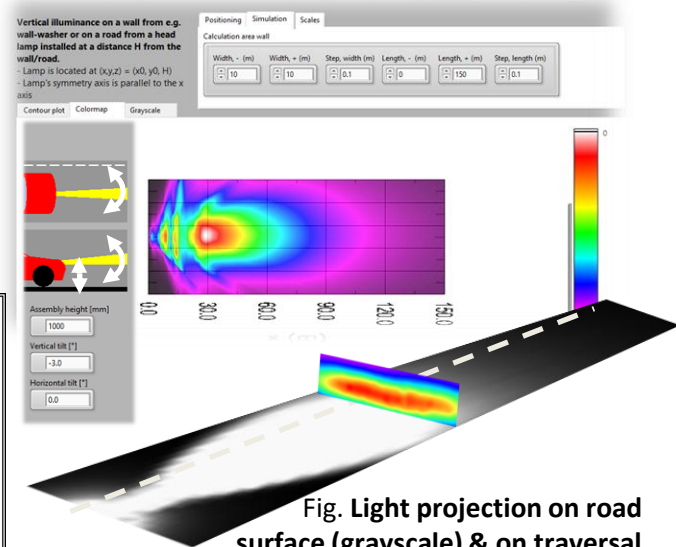

Fig. Light projection on road surface (grayscale) & on transversal plane at 50m distance (color).

A/B Type Goniophotometer - Software Features

Candela tool for Elevation and Azimuth angles

- ✓ PASS/FAIL Test according to different standards such as ICAO, CAP437, FAA, HMS where luminous intensity specification is given as a function of elevation angle being identical at all azimuth angles.
- ✓ Useful test tool for checking standard compliance of photometric performance of rotation-symmetric signal lights such as aeronautical, helideck lights
- ✓ The angular luminous intensity distribution of luminaire/lamp is measured with normal IES/LDT angular scan using an angular range required in the standard.
- ✓ The GPM software includes some pre-defined test specifications e.g. CAP437 and ICAO omnidirectional lights.
- ✓ A test specification editor allows a user to create new test specifications (see Fig.).
- ✓ Compatible with A and C type goniophotometers

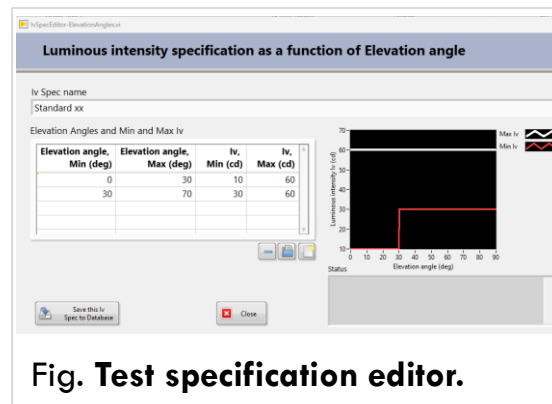

Fig. Test specification editor.

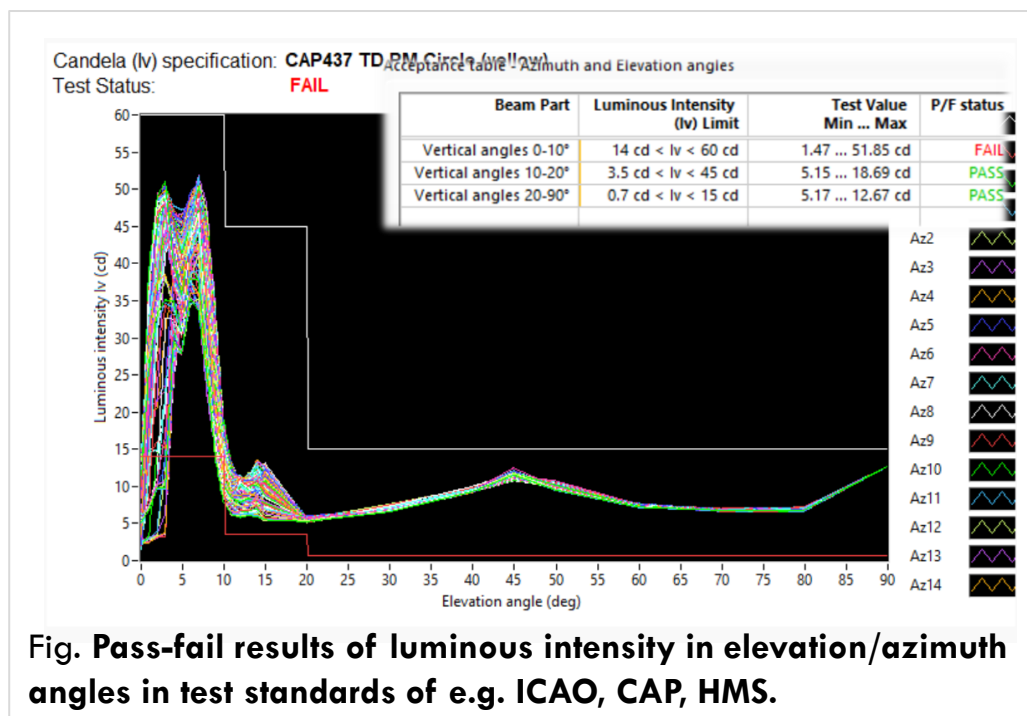

Fig. Pass-fail results of luminous intensity in elevation/azimuth angles in test standards of e.g. ICAO, CAP, HMS.

A/B Type Goniophotometer - Software Features

Candela tool for horizontal and vertical angles (Iv-Spec-sw)

- ✓ PASS/FAIL Test according to test standards such as ICAO, FAA, ECE, FVMSS108...
- ✓ Luminous intensity specification is defined in horizontal and vertical angles.
- ✓ **Editor of Candela test specification** (see next page) is add-on sw tool for both GPM sw (turning goniometer) and BTC sw (camera+screen based goniometer).

1. Test by Candela tool -sw:

- a. Luminous intensity is measured only in the places (e.g. single test points, zones...) where the luminous intensity specification is defined.
- b. Test Time: typically <10 minutes.

2. Test with a Full-scan:

- a. The complete angular luminous intensity distribution of luminaire/lamp is measured in an angle range required by the standard.
- b. The test produces the overall beam information such as beam shape, beam angle, maximum luminous intensity, iso-lux curves...
- c. The angle position of the lamp can be fine-adjusted for reaching Pass result.
- d. Test time: from several tens of minutes up to 10 hours.

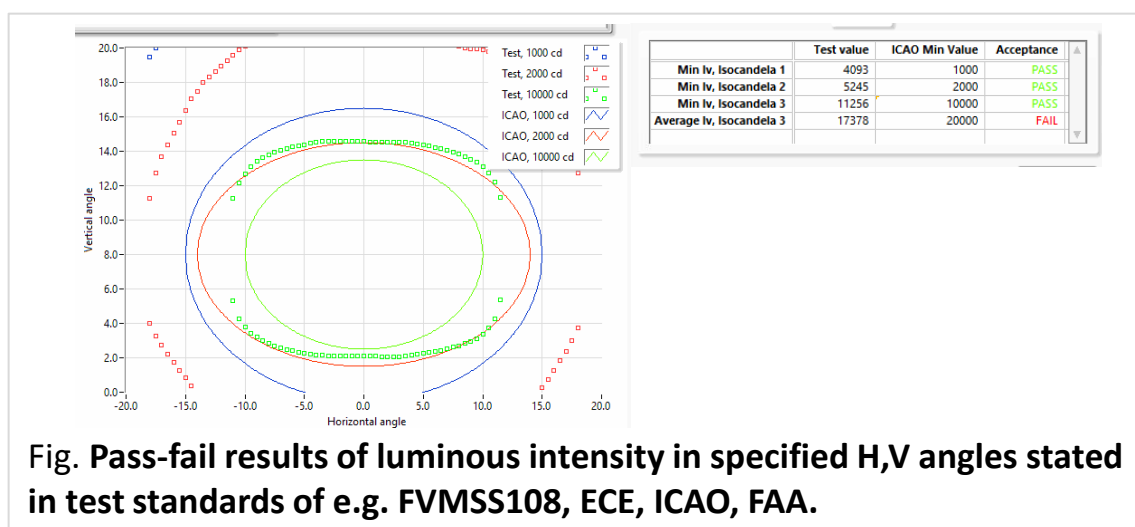

Fig. Pass-fail results of luminous intensity in specified H,V angles stated in test standards of e.g. FVMSS108, ECE, ICAO, FAA.

A/B Type Goniophotometer

- Software Features

Editor of Candela Test Specification

Using this editor the sub-test specifications (e.g. Groups, Zones) can be created, removed and edited. The overall Candela Test Specifications can be created by combining these sub-test specifications.

Different sub-test specifications:

- ✓ *Single test point:* Min and Max luminous intensity (Iv)
- ✓ *Group of test points:* Min/Max Iv of Any test point, Min/Max of Sum Iv of all test points, and Min/Max of Average Iv of all test points.
- ✓ *Line or Segment:* Min/Max Iv of Any test point in the line, and Min/Max of Average Iv of all test points in the line.
- ✓ *Zone or Area:* Min/Max Iv of Any test point in the zone, Min/Max of Average Iv of all test points in the zone, Min/Max of Maximum Iv, and Min/Max of Minimum Iv.
- ✓ *Cutoff (R149 specific):* Vertical and horizontal cutoff sharpness of automotive lights according to UN ECE R149.
- ✓ *Stability:* Defines criteria when the luminous intensity values are measured.
- ✓ *CIE1931:* Color coordinate test specification. User-defined parameters:
 - **Color specification** for CIE1931 color diagram (e.g. ICAO, IALA).
 - **Color class** defines the chosen color area defined in the Color specification.
 - Color spec can be tested at different **angles** and **stability times**

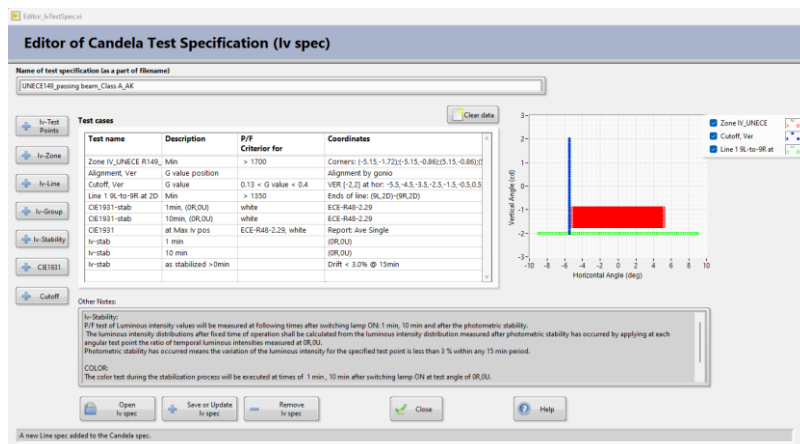

Measurement Ranges - Goniophotometer

Photometer		SSL LC-800.1		
Measuring head		SSL LH1010-f3, Silicon photodiode with V(λ) filter. The spectral match to CIE photopic sensitivity curve $f_1' < 3\%$ (class A)		
Min. luminous intensity accuracy		$> \pm 2.5\%$ (k=2), depends on the angular beam shape of DUT		
Luminous flux accuracy		$\pm 3\%$ (k=2)		
Luminous intensity range (measurement distance)		0.001 – 600 000 cd (1 m) 0.009 – 5 500 000 cd (3 m) 0.03 – 15 000 000 cd (5 m) 0.07 – 39 000 000 cd (8 m) 0.10 – 61 000 000 cd (10 m) 0.23 – 130 000 000 cd (15 m) 0.41 – 240 000 000 cd (20 m) 2.6 – 1 500 000 000 cd (50 m)		
Luminous flux range	Test distance	Isotropic radiation (uniform over the γ range $\pm 180^\circ$)	Lambertian radiation, γ range $\pm 90^\circ$	Narrow beam radiation with 40° beam angle [$\cos^n(\theta)$ type beam], γ range $\pm 90^\circ$
	1 m	0.01 lm – 7.2 E+6 lm	0.03 – 1.8E+6 lm	0.006 – 3.0E+5 lm
	3 m	0.1 lm – 6.6E+7 lm	0.3 – 1.6E+7 lm	0.055 – 2.8E+6 lm
	5 m	0.3 lm – 1.8E+8 lm	0.9 – 4.5E+7 lm	0.15 – 7.6E+6 lm
	8 m	0.8 lm – 4.6E+8 lm	2.0 – 1.1E+8 lm	0.39 – 1.9E+7 lm
	10 m	1.2 lm – 7.3E+8 lm	3.2 – 1.8E+8 lm	0.61 – 3.0E+7 lm
	15 m	2.8 lm – 1.5E+9 lm	7.1 – 3.9E+8 lm	1.4 – 6.6E+7 lm
	20 m	4.9 lm – 2.8E+9 lm	13 – 7.2E+8 lm	2.4 – 1.2E+8 lm
50 m	31 lm – 1.8E+10 lm	79 – 4.5E+9 lm	15 – 7.6E+8 lm	

Measurement Ranges - Goniophotometer

Photometer		SSL L-51																										
Measuring head		SSL LH66-f3, Silicon photodiode with $V(\lambda)$ filter. The spectral match to CIE photopic sensitivity curve $f_1' < 3\%$ (class A)																										
Min. luminous intensity accuracy		$> \pm 2.5\%$ ($k=2$), depends on the angular beam shape of DUT																										
Luminous flux accuracy		$\pm 3\%$ ($k=2$)																										
Luminous intensity range (measurement distance)		<table border="0"> <tr><td>0.003 –</td><td>3 000 cd</td><td>(1 m)</td></tr> <tr><td>0.027 –</td><td>27 000 cd</td><td>(3 m)</td></tr> <tr><td>0.08 –</td><td>75 000 cd</td><td>(5 m)</td></tr> <tr><td>0.19 –</td><td>190 000 cd</td><td>(8 m)</td></tr> <tr><td>0.30 –</td><td>300 000 cd</td><td>(10 m)</td></tr> <tr><td>0.68 –</td><td>670 000 cd</td><td>(15 m)</td></tr> <tr><td>1.20 –</td><td>1 200 000 cd</td><td>(20 m)</td></tr> <tr><td>7.5 –</td><td>7 500 000 cd</td><td>(50 m)</td></tr> </table>			0.003 –	3 000 cd	(1 m)	0.027 –	27 000 cd	(3 m)	0.08 –	75 000 cd	(5 m)	0.19 –	190 000 cd	(8 m)	0.30 –	300 000 cd	(10 m)	0.68 –	670 000 cd	(15 m)	1.20 –	1 200 000 cd	(20 m)	7.5 –	7 500 000 cd	(50 m)
0.003 –	3 000 cd	(1 m)																										
0.027 –	27 000 cd	(3 m)																										
0.08 –	75 000 cd	(5 m)																										
0.19 –	190 000 cd	(8 m)																										
0.30 –	300 000 cd	(10 m)																										
0.68 –	670 000 cd	(15 m)																										
1.20 –	1 200 000 cd	(20 m)																										
7.5 –	7 500 000 cd	(50 m)																										
Luminous flux range (lm)	Test distance	Isotropic radiation (uniform over the γ range $\pm 180^\circ$)	Lambertian radiation, γ range $\pm 90^\circ$	Narrow beam radiation with 40° beam angle [$\cos^n(\theta)$ type beam], γ range $\pm 90^\circ$																								
	1 m	0.04 – 3.6E+4	0.1 – 9.0E+3	0.02 – 1.5E+3																								
	3 m	0.3 – 3.2E+5	0.8 – 8.1E+4	0.2 – 1.4E+4																								
	5 m	0.9 – 9.0E+5	2.3 – 2.3E+5	0.5 – 3.8E+4																								
	8 m	2.3 – 2.3E+6	6.0 – 5.7E+5	1.2 – 9.7E+4																								
	10 m	3.6 – 3.6E+6	9.3 – 9.0E+5	1.8 – 1.5E+5																								
	15 m	8.1 – 8.0E+6	21 – 2.0E+6	4.1 – 3.4E+5																								
	20 m	14 – 1.4E+7	37 – 3.6E+6	7.2 – 6.1E+5																								
50 m	90 – 9.0E+7	240 – 2.3E+7	45 – 3.8E+6																									

GONIOPHOTOMETER (B and C TYPE) LABORATORY SETUP

STANDARD SETUP

The arrangement of the goniometer station, photometer and spectrometer (option) is shown in figure below. The software has feature to setup the angles and distances of each sensor, then the measurements are made automatically with both sensors.

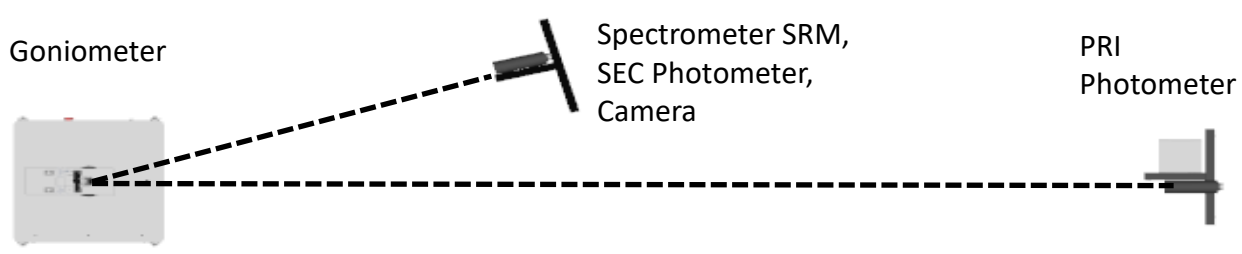

Fig. Room size 9m x 2.4m for measuring 1.5m luminaires at 7.5m test distance.

GONIO SETUP with Distance Extension Mirror (DEM)

In case of limited or relatively small gonio room available, the measurement distance can be extended using a mirror. As a result, the arrangement allows to measure large luminaires in a smaller room as the mirror duplicates the test distance.

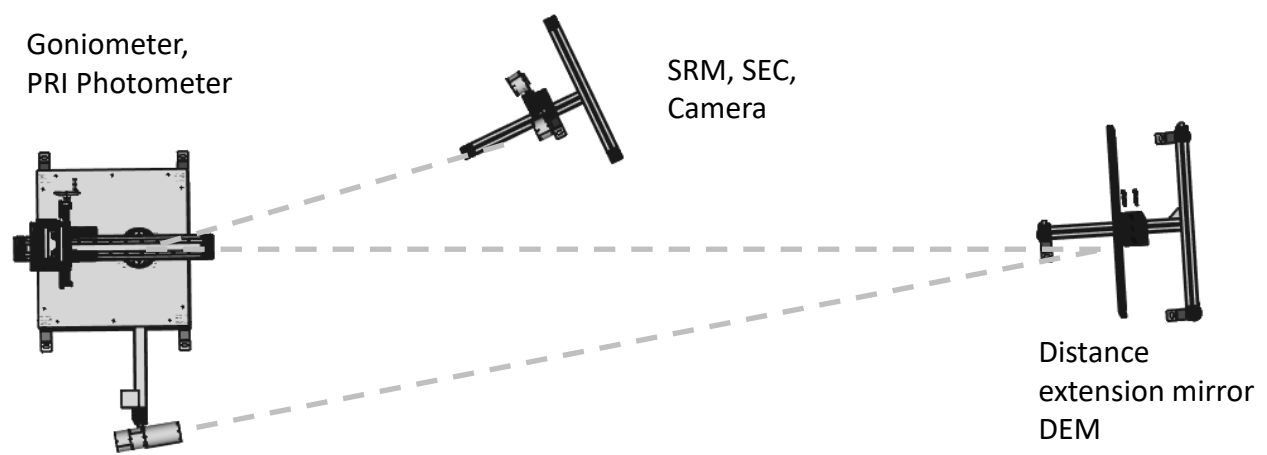

Fig. Room size 5m x 2.5m for measuring 1.5m luminaires at 7.5m test distance.

GONIOPHOTOMETER LABORATORY SETUP

PREPARING LABORATORY

With attaching the photodetector to a stray light tube, the laboratory preparation is much easier. The stray light from the side wall, ceiling and floor is eliminated by a stray light tube (SLET) having a couple of apertures with a knife edge land. The photometer can see reflections only from the back-wall behind the goniometer station, so it is the only that needs to be covered by a special black surface. The stray light tube also allows use of roof lighting in the photometer end of the gonio lab making more more comfortable working area in the lab. The stray light tube is assembled at a fixed photometric distance according to the largest possible test sample. This reduces the risk of erroneous distance setting.

Example setup below:

LUMI 180 H BPC + DEM + SRM motorized

Measurement distance: 12 m (photometer), 5m (Spectroradiometer)

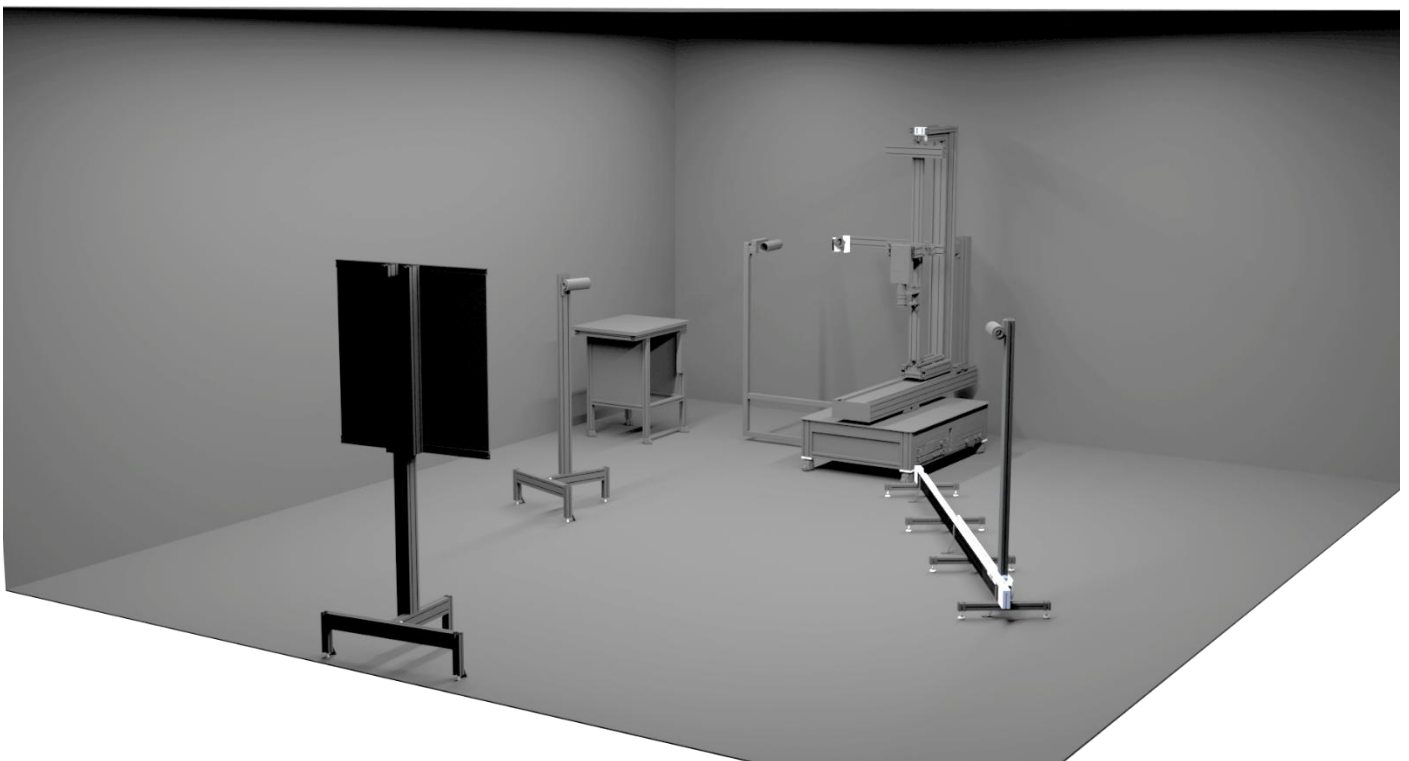

GONIOPHOTOMETER LABORATORY SETUP



EQUIPMENT HOLDER and PC TABLE

Goniometer peripherals (powering equipment and gonio controller) and test computer with display can be installed onto the SSL RACK-2 which has a 19" rack equipment. It is easily movable using castor with a wheel and adjustable foot.

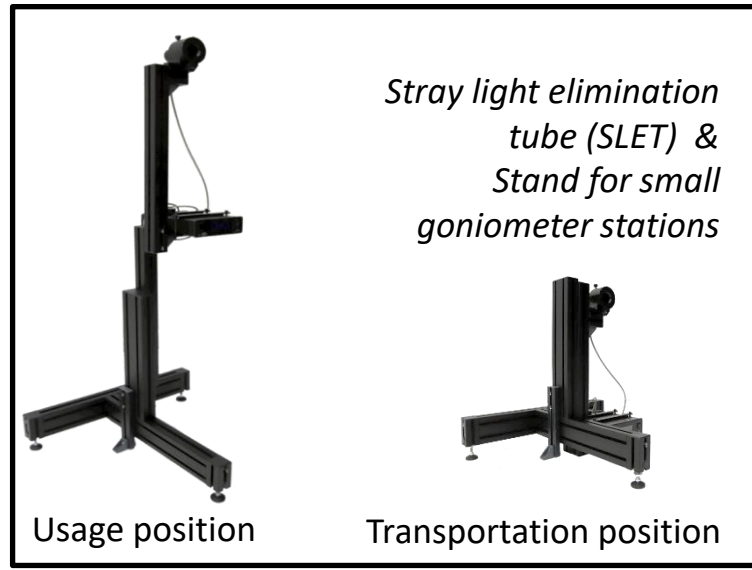

REMOTE CONTROL APP (LUMI series)

The goniometer station can be custom rotated by Remote control MC20x_BT -app. The photometer positions can be stored in the app in similar way as in PC software. There are Advanced view (left) and Basic view (right)

GONIOPHOTOMETER LABORATORY SETUP

Photometering versions

Far field photometer Primary photometer for measuring luminous intensity at far field. The goniometer can be equipped by any SSL photometer for luminous intensity (I_v) distribution measurements. The photometer has a range of measuring heads for choice of illuminance measurement range.

Far field colorimeter The goniometer can be equipped by any SSL colorimeter for measurements of I_v , color temperature (CCT) and color coordinates, and angular color uniformity (SDCM). The SSL colorimeter has a range of measuring heads for choice of illuminance measurement range and CIE 1931 XYZ spectral match accuracy.

Secondary photometer Secondary photometer for measuring low luminous intensity levels / flicker at a shorter distance

Spectro-radiometer The goniometer can be equipped by any SSL spectroradiometer for measurements of spectral radiant flux, CCT, CRI, TM30-18 indices, SDCM and many other spectral related parameters. The SSL product range contains spectroradiometers with different wavelength ranges, spectral irradiance detectivity and the optical bandwidth.

SAVE TIME, SPACE AND MONEY

- ✓ Straightforward setup (no measurement rail needed)
- ✓ User-friendly and versatile test software
- ✓ Easy-to-use Sample holder, installation and training service, etc.
- ✓ Fast colorimetric measurements

SSL GONIOPHOTOMETER

Add-on features

Camera (IMG-2)

Feature	Designator	Minimum Setup add-on ^{*)}
Luminous area (LA)	Manual / simple threshold analysis	IMG-2 ¹⁾
Position of LA center	Up to five (5) directions	IMG-2 ¹⁾
Turning axis adjustment	depth	IMG-2 ¹⁾ + 3 rd axis ³⁾
Turning axis adjustment	C plane	IMG-2 ¹⁾
Camera aligning tool	Positioning of light detectors	IMG-2 ¹⁾
CIE 232 luminous area	Manual / Automatic rotation	IMG-2.Lv ²⁾ + FiLMI.base sw + CIE232 sw
Luminance image	Gonio rotation possible	IMG-2.Lv ²⁾ + FiLMI.base sw

^{*)} Setup needs a Stand if it is not yet available for camera or spectroradiometer.

¹⁾ IMG-2 contains CAM2.3 and IMG-2 sw

²⁾ IMG-2.Lv contains CAM2.3.Lv-f3 luminance camera and IMG-2 sw

³⁾ 3rd axis is the motorized vertical arm of goniometer station (LUMI 180.3, LUMI 120.3, HEVI 1700.3)

Secondary photometer

Test parameter	Designator / Application	Minimum Setup add-on ^{*)}
Luminous intensity	Low luminous intensity / standard specified distance	L-51 + LH1010-fx + Tube-55-xx
Flicker	Flicker index/frequency, Percent flicker, SVM, PstLM	L-50 + LH1010-f10 + Tube-55-xx + GPM-Flicker sw
Effective intensity & Flash duration	Modified Allard, Allard, Blondell-Rey, Modified Blondell-Rey	L-50 + LHxx-fx + Tube-55-xx + GPM-El sw

^{*)} Setup needs a Stand if it is not yet available for camera or spectroradiometer.

MEASUREMENT SCHEMES

Photometer

- | | |
|------------|--|
| On-the-fly | <ul style="list-style-type: none"> - Light measurement is taken during the angular rotation without stopping the rotation. - Fast and stable enough. - Test time: 15-18s per C plane (0.5° angle step). The test time can be adjusted by user-defined parameters. |
| Stop&Go | <ul style="list-style-type: none"> - Goniometer is turned – stopped – photometer is measured – goniometer is turned – gonio is stopped - Useful in case where the slow pulsing lights or astable lights are measured. - More stable, slower. |

Spectroradiometer (SRM)

- | | |
|--------------|--|
| Motorized | <ul style="list-style-type: none"> - Motorized bench to adjust the measurement distance to optimal obtain the integration time |
| Auto-range | <ul style="list-style-type: none"> - Exposure (or integration) time adapts to changing light levels. The optimal integration time is defined in each angular position. - Slow, more accurate. |
| Fixed-auto | <ul style="list-style-type: none"> - The fixed integration time is determined at the direction of the maximum intensity is optimal. - Is used in case of connected photometer measurement. - Faster, reasonably accurate, Automatic operation.' |
| Fixed-manual | <ul style="list-style-type: none"> - The fixed integration time is determined manually by user - Is used in pure spectral measurement without photometer measurement. - Faster, reasonably accurate, Manual operation. |

Type C Goniophotometers

Model	Length (cm)	Thickness (cm)	Mass (kg)	Lamps, E27/E14,...	Tube Lamps	LED modules	Flash lights	LED strip	Down lights	LED Panel	Large Linear	Heavy Flood	Street lights	Automotive	Decorative	CIE S025 compatibility	Option: SSL-ALI	Option: SSL-BPC	Option: B type
SSL LAMP 30	30	30	3	X			X												X
SSL LAMP 200	200	10	4		X	X		X	(X)	X						(X)		X	
SSL LEDI 70	70	15	3			X			X	X									
SSL LUMI 30 P	30	13	3	X			X												
SSL LUMI 90	90	30	9	X		X	X	X	X	X						(X)		X	
SSL LUMI 120	120	80	20	X	X	X	X	X	X	X		X		X		(X)		X	X
SSL LUMI 130 L	130	30	8	X	X	X	X	X	X	X		X		X		(X)		X	
SSL LUMI 180	180	60	25	X	X	X	X	X	X	X	X		X	X	(X)	(X)	X	X	X
SSL LUMI 180 H	180	100	50	X	X	X	X	X	X	X	X	X	X	X	(X)	(X)	X	X	X
SSL LUMI 180 BPC	180	40	15	X	X	X	X	X	X	X	X		X	X	(X)	X	X		X
SSL LUMI 180 H BPC	180	60	35	X	X	X	X	X	X	X	X	X	X	X	(X)	X	X		x
SSL DECO 27	27	30	6	X		X	X		X						X	X			



SSL LUMI series

Solution for testing any size of luminaires for general lighting, street lighting or automotive lighting.

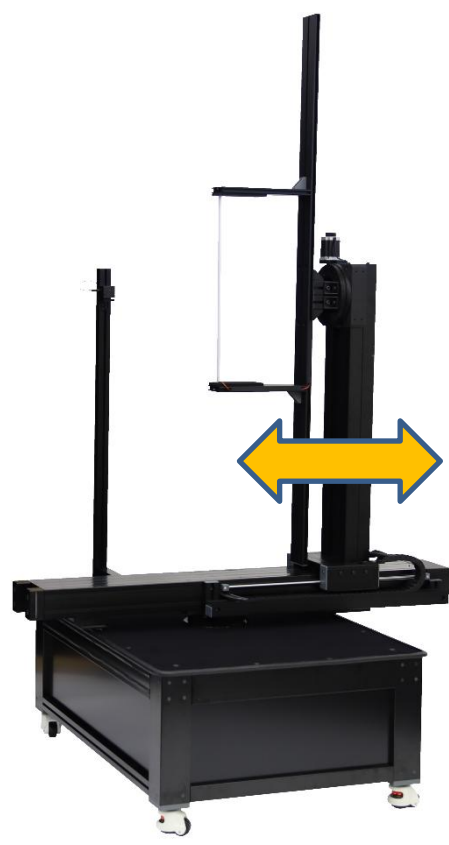

B Type Measurement for Automotive Lights
(photo: SSL LUMI 120)

- Innovative Mechanical Structure** (photo: SSL LUMI 180)
- Integrated electrical device rack for space saving solution
 - Leveling castors for easier moving and installation
 - Motorized vertical arm and camera for automatic adjustment of the turning axis

Burning position correction for B and C type measurement to meet CIE S025 standard.



Burning Position Correction Setup for B type (photo: SSL LUMI 120)



Burning Position Correction Setup for C type (photo: SSL LUMI 90)

SSL LUMI series

NEW

LUMI 30 P

- ✓ Portable
- ✓ Fits in PELI 1660 case
- ✓ Adjustable distance

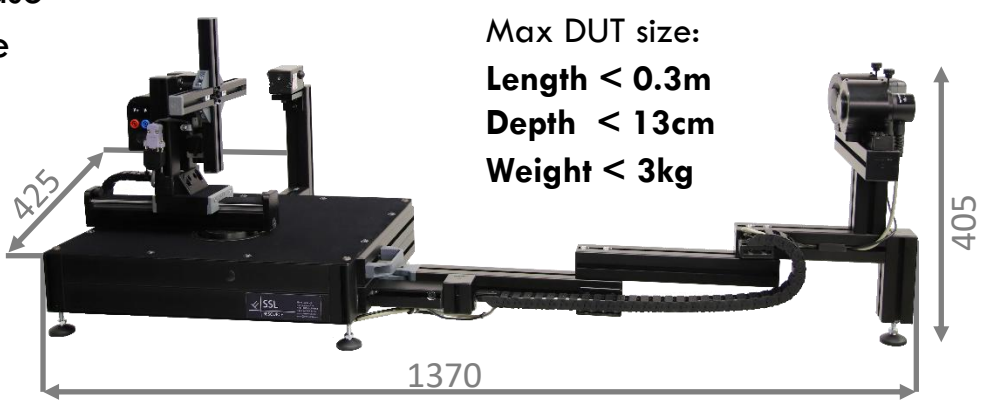

Max DUT size:
Length < 0.3m
Depth < 13cm
Weight < 3kg

Standard LUMI 30 P includes 1 pc of stray light tube.

LUMI 130 L



Max DUT size :

Length < 1.3m

Depth < 30cm

Weight < 8kg

LUMI 90



Max DUT size :

Length < 0.9m

Depth < 30cm

Weight < 9kg

SSL LUMI series

NEW



LUMI 180 H

Heavy-duty Mechanical Structure

- For widest and heaviest lighting fixtures
- Wide adjustment range for thickness
- Option: Integrated BPC for standard compliance

Max DUT size:
Length < 1.8m
Depth < 100cm
Weight < 50kg



LUMI 180

- ✓ Best seller
- ✓ Option: Integrated BPC

Max DUT size:
Length < 1.8m
Depth < 60cm
Weight < 25kg

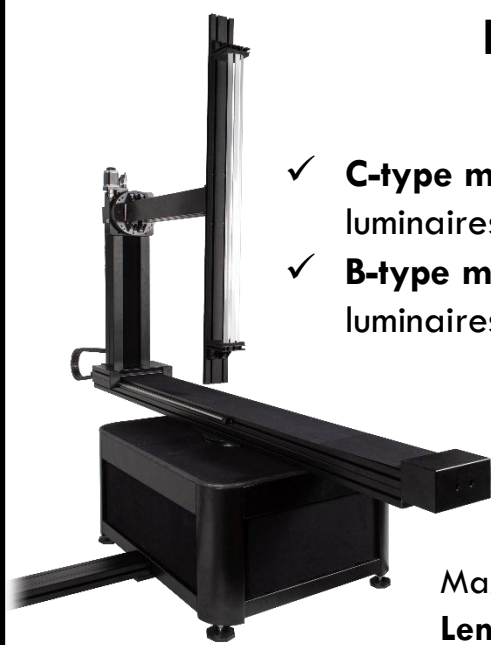

LUMI 120

- ✓ **C-type mode:** For thick luminaires (<80 cm)
- ✓ **B-type mode:** For long luminaires (<160 cm)

Max DUT size:
Length < 1.2m
Depth < 80cm
Weight < 20kg

Datasheet

SSL LUMI series

PRODUCT	SSL LUMI 90	SSL LUMI 130 L	SSL LUMI 120	SSL LUMI 180	SSL LUMI 180 H
Product code	C-1R.9-90-30	C-1R.8-130-30	C-1R.20-120-80	C-1R.25-180-60	C-1R.50-180-100
Application area	small-medium sized SSL luminaires (LED panels / downlights)	lightweight medium sized linear lights, LED panels / downlights	long automotive headlamps, general lighting fixtures	long automotive headlamps, general lighting fixtures	long and heavy automotive headlamps, general lighting fixtures
Goniometer type	C type (B type) with horizontal optical axis one column (two columns) arrangement				
Gonio controller	2/3 axis Stepper controller (19" 1U, RS-232) Worm gear drive system with deep groove ball bearings				
Alignment laser	Red cross-line laser (5mW)				
Arrangement	Goniometer station with electrical device 19" rack integration				
19" Rack space	6U in one column	6U in one column	4U in one column	8U in two columns	6U (700mm depth), 16U (350mm depth)
Gonio dimensions	1.2m, 0.63m, 0.6m, 50kg	1.4m, 0.63m, 0.6m, 52kg	1.3 m, 0.6 m, 0.8 m, 120kg	1.6 m, 1.3 m, 0.9 m, 160kg	1.6 m, 1.4 m, 0.94 m, 250kg
Height of optical axis	1.1 m	1.3 m	1.3 m	1.5 m	1.5 m
B-DUT ¹ : L x H x T, m	0.6m x 0.5m x 0.1m, 10kg	0.6m x 0.8m x 0.1m, 10kg	1.6m x 0.8m x 0.3m, 20kg	1m x 1m x 0.3m, 40kg	1.8m x 1m x 0.5m, 50kg
C-DUT ¹ : D x T, m	0.9m x 0.3m, 9kg	1.3m x 0.3m, 8kg	1.2m x 0.8m, 20kg	1.8m x 0.6m, 25kg	1.8m x 1m, 50kg
Minimum space for lab room (WxH, Length L) ²	1.1 m x 1.7 m, L: 5.5 m (C), 10 m (B)	1.5 m x 2 m, L: 8 m (C), 20 m (B)	3.5 m x 2.2 m, L: 8 m (C), 20 m (B)	2.7 m x 2.5 m, L: 10 m (C), 17 m (B)	3 m x 2.5 m, L: 10 m (C), 17 m (B)
Angular range	±175° (γ axis), 0-360° (C plane axis)				
Resolution / Accuracy	<0.006° / <0.1° (γ and C axes)				

¹Maximum dimensions of the luminaire under test (DUT): L=Length, W=Width, T=Thickness (B type), Diagonal D = (L²+W²)^{1/2}, T=Thickness (C type). m = mass (kg)

²On the basis of the photometric distances: 15 x "luminous area length" for automotive lamps (B type), 5 x "luminous area length" for C type measurements

SSL DECO 27

- ✓ Completely meets the CIE S025 requirements for unchanged burning positions.
- ✓ Opportunity to measure photometrics of lighting fixtures with movable parts.
- ✓ Motorized axis for setting any burning position
- ✓ No separate lamp holder stand needed.

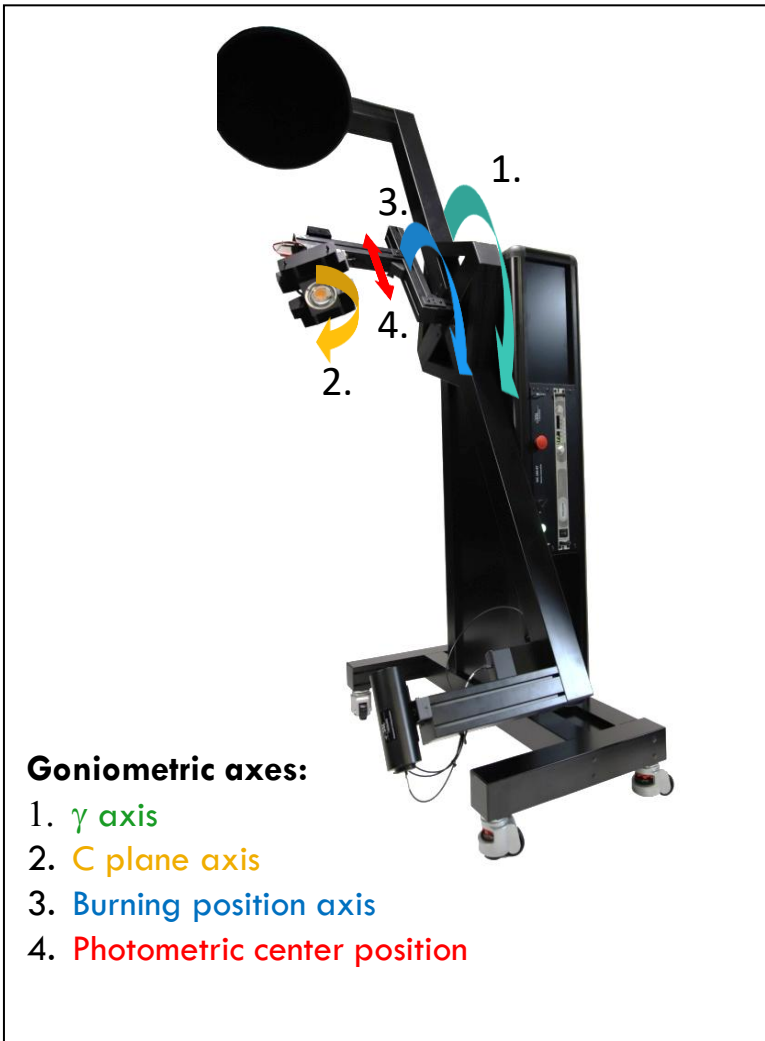

SAVE TIME, SPACE AND MONEY

- ✓ Compact setup saves even 70% room footprint size
- ✓ Mobile and stable
- ✓ Ready to use in your office.
- ✓ No need for dark room.
- ✓ Suitable also for production tests.

Optimal for testing burning position sensitive luminaires with a luminous area <270 mm.

SSL DECO 27 - Specification

Goniometer model	SSL DECO 27	
Product code	SSL C-2R.270	SSL C-2.custom
Application area	Small and medium sized LED modules and luminaires, burning position sensitive luminaires,	
Goniometer type	C type with vertical optical axis. Floor mount goniometer of type 2.1 (EN13032-1:2004 clause 6.1.1.2) with the turning detector (γ axis) and luminaire (C axis) features. Completely meets the requirements of unchanged burning positions stated in IES LM79-08 Clause 9.3.1.	
Gonio driver and controller	3 axis Stepper motor controller with RS-232 / USB interface, Worm gear drive system with deep groove ball bearings	
Alignment laser	Red cross-line laser (5mW)	
Goniometer arrangement	Goniometer station with electrical device 19" rack integration (unoccupied 5U for AC/DC power supply / meter)	
Height, Width, and Length	1.5 m, 1.2 m, 0.8 m	
Measurement distance	1.3 m	
Max luminaire size for LID ¹ (or flux)	27 cm (45 cm)	
Max total length, depth and mass of DUT ²	50 cm, 30 cm, 6kg	
Minimum space requirement (WxHxL)	1 m x 2.7 m x 2.7 m	Room height 2.5-5m
Luminous intensity range	0.002 – 130 000 cd	
Resolution	<0.01° (C and γ axis), <0.05° (Burning position axis)	
Reproducibility / Accuracy	<0.1° (C and γ axis), <0.5° (Burning position axis)	

¹LID - Luminous Intensity Distribution,

²DUT - Device under test

SSL LAMP 30

For flash/torch lights, LED lamps, small LED modules <300 mm.



C type configuration



B type configuration (B type option, SSL C-1.30.B)

SSL LEDi 70

For LED modules and thin luminaires <700 mm.

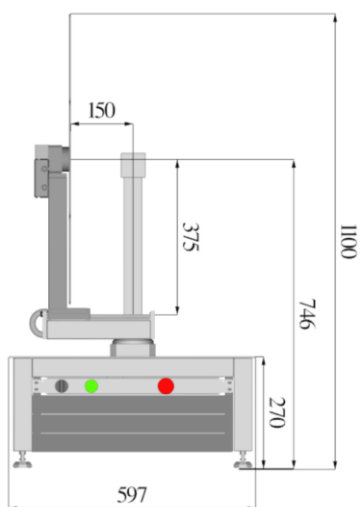

SSL LAMP 200

For LED strips and tubes < 2 m, <13cm thick

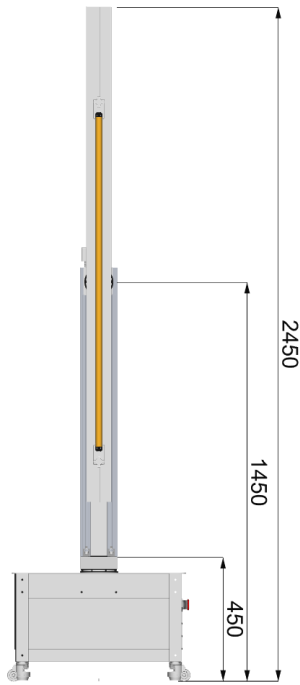

SSL UNI 170

Low-cost goniometer for luminaires <1.7 m and <10kg

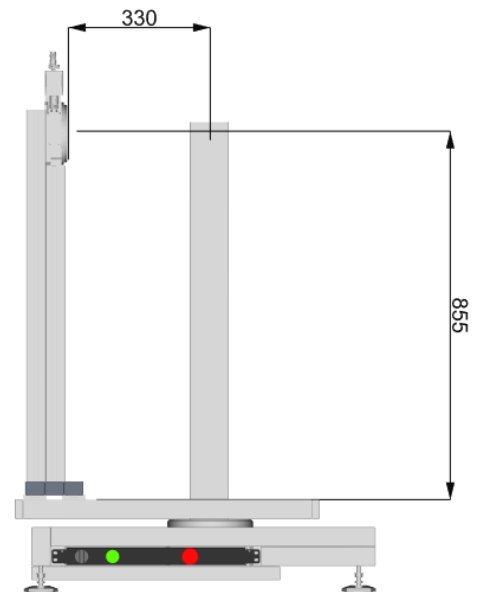

Datasheet

SSL C-1 Goniometer family

Goniometer	SSL LAMP 30	SSL LAMP 200	SSL LEDI 70	SSL UNI 170
Product code	C-1.3-34-30	C-1.4-200-12	C-1.3-70-15	C-1.16-170-30
Goniometer type	C type with horizontal optical axis.			
Gonio driver and controller	2 axis Stepper motor controller with RS-232 / USB interface, Worm gear drive system with deep groove ball bearings. Emergency stop switch.			
Goniometer arrangement	Goniometer station and the electrical device rack holder are in separate units.			
Alignment laser	Red cross-line laser (5mW)			
Gonio Height x Width x Length (cm)	52 x 75 x 60	235 x 65 x 65	110 x 75 x 60	200 x 100 x 120
Height of optical axis (Appr.)	0.36 m	1.5 m	0.75 m	1.1 m
Max length, depth and mass of DUT	34cm, 30cm, 3kg	200cm, 13cm, 3kg	75cm, 15cm, 3kg	170cm, 30cm, 10kg
Resolution	<math><0.01^\circ</math> (C and γ axis)			
Reproducibility / Accuracy	<math><0.1^\circ</math> (C and γ axis)			
Minimum room space Width x height x length (m)	0.8 x 0.8 x 3	2.5 x 2.5 x 12 2.5 x 2.5 x 7 (DEM)	0.8 x 0.8 x 6 0.8 x 0.8 x 3.5 (DEM)	2.5 x 2.5 x 10 2.5 x 2.5 x 6 (DEM)

Type B/A Goniophotometers

Model	Type	Length (cm)	Thickness (cm)	Height (cm)	Mass (kg)	Automotive	Marine lights	Airfield Lights	Torch lights	Bicycle lights	Traffic lights	Warning Lights	VMS	Railway Lights	Street lights	Flood Lights
SSL LAMP 30.B	B*	30		20	3	x			x	x						
SSL LUMI 120.B	B*	180		80	20	x		(x)	x	x	x	x	x	x		
SSL LUMI 180.B	B*	100		100	25	x		(x)	x	x	x	x	x	x		
SSL AUTO 50.A	A	60		25 ¹⁾	5	x	x	x			x	x				
SSL AUTO 100	B	60		50	10	x		(x)	x	x	x	x	x	x		
SSL AUTO 140.B	B	140		60	20	x		(x)	x	x	x	x	x	x		
SSL AUTO 500	A	100		60 ¹⁾	30	x	x	x								
SSL AUTO 1000	A	100		100 ¹⁾	50	x	x	x			x	x	x	x	x	x

¹⁾Type A goniometers: measured from the bottom to turning center of α axis

* Accessory for C-type Goniophotometer



Type B GONIOPHOTOMETER SSL AUTO 100

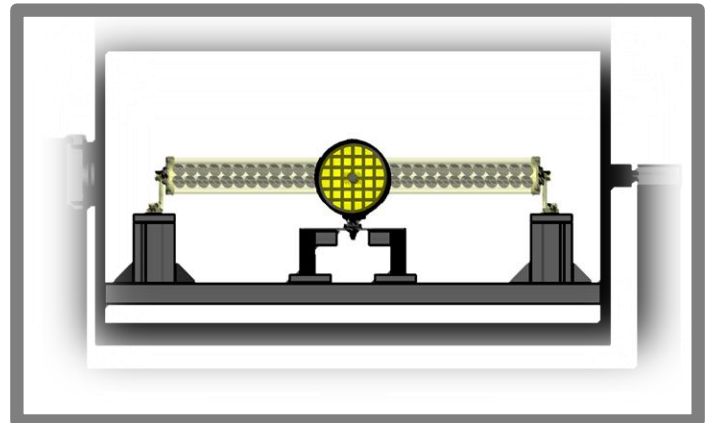
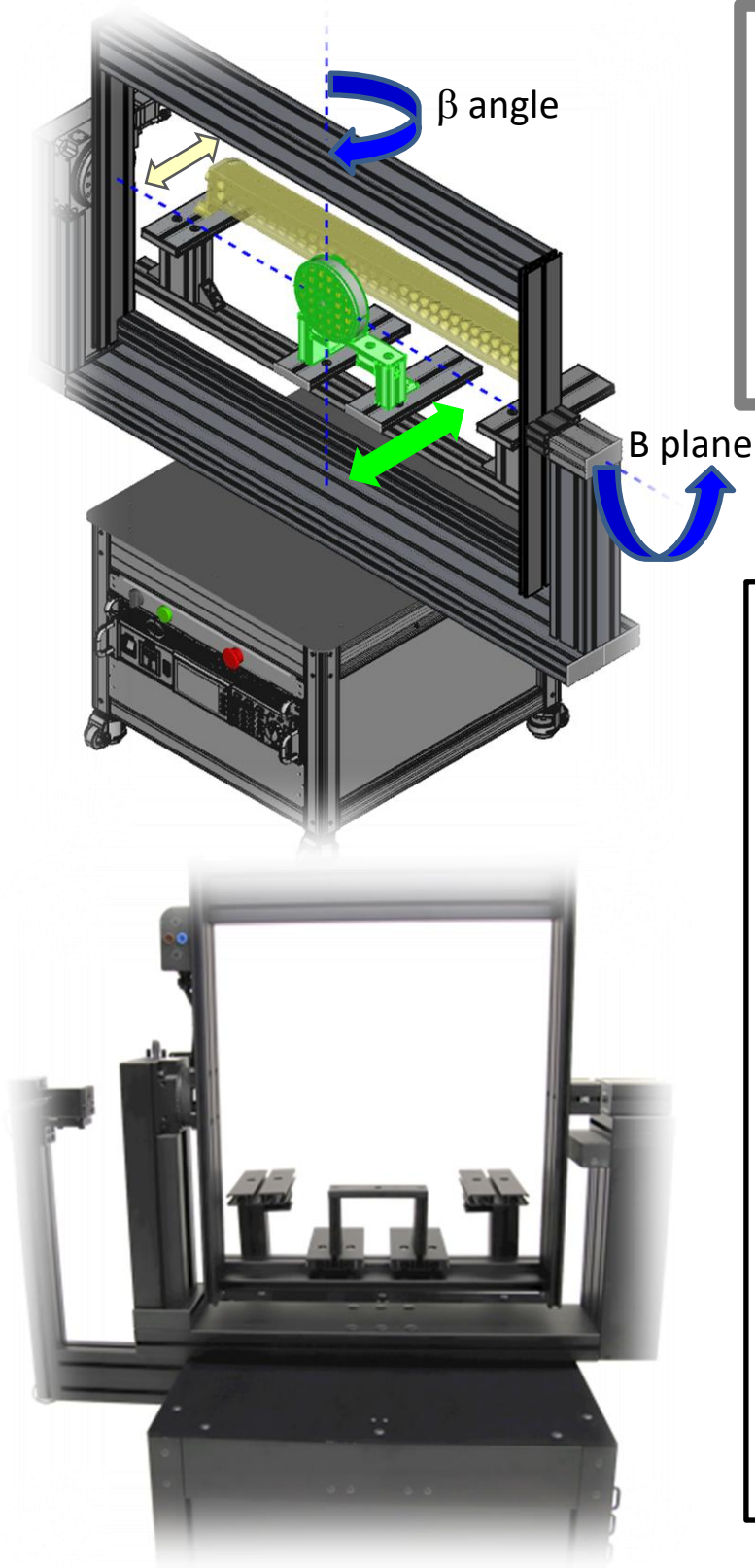

Fig. Dedicated sample holder enables simultaneous usage for round and linear lights .



AUTO 100

- B type goniophotometer
- Samples up to 0.6m, 10kg

Type B GONIOPHOTOMETER SSL AUTO 140

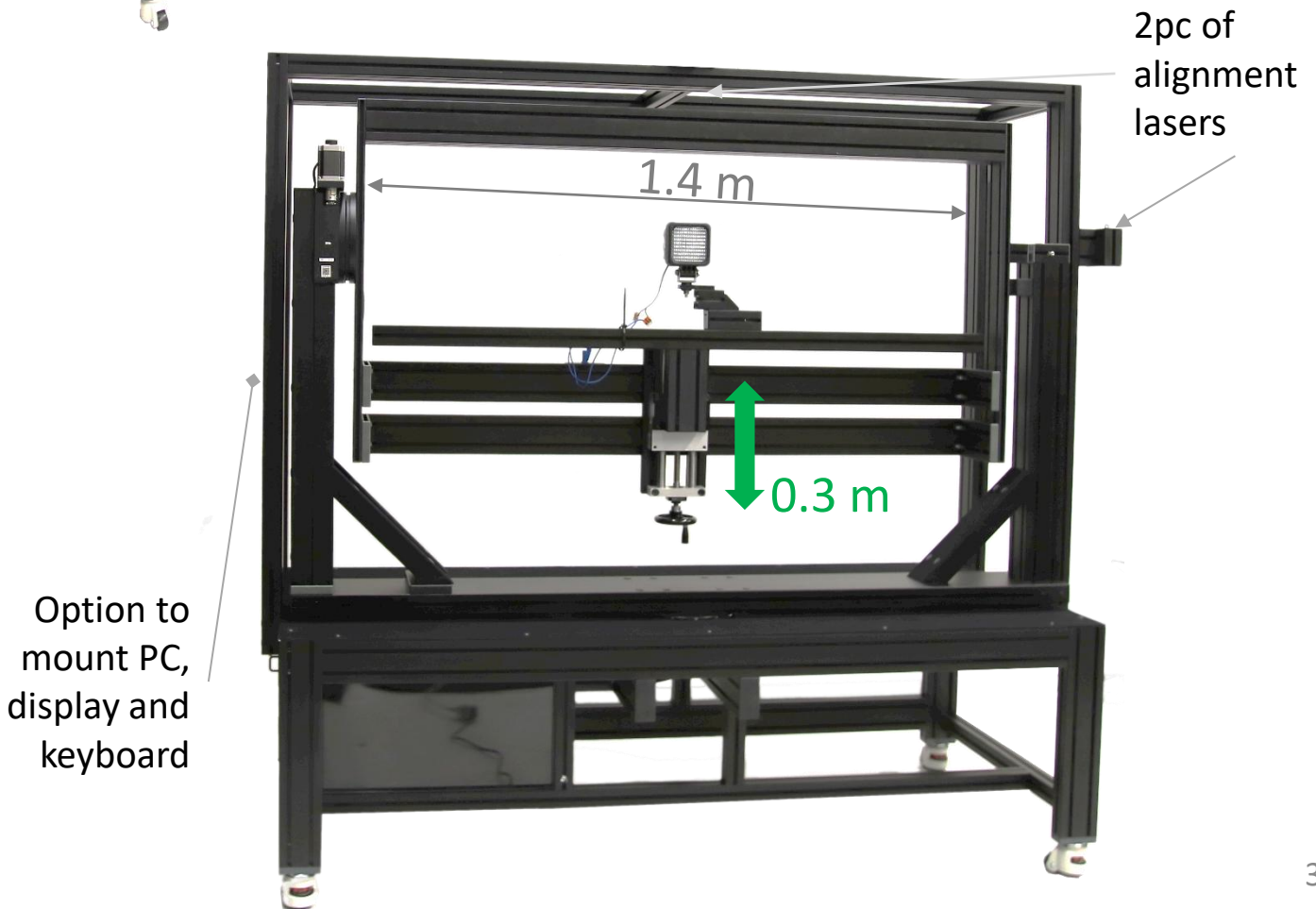
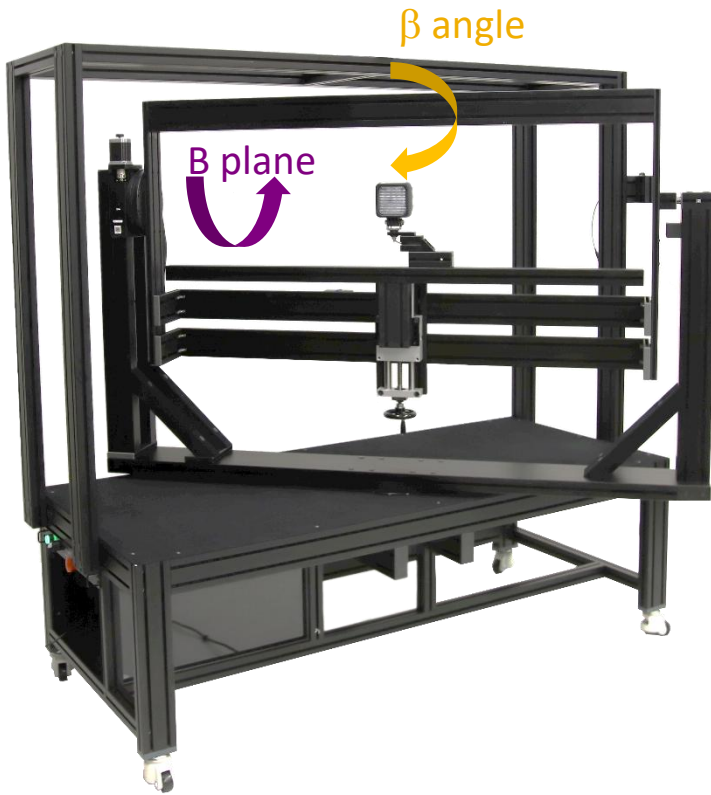

Type B GONIOPHOTOMETER - Specification

Goniometer	SSL AUTO 100	SSL AUTO 140
Product code	B.100	B.140
Application area	For Railway and automotive lights	
Goniometer type	B type	
Gonio driver and controller	2 axis Stepper motor controller with RS-232 / USB interface, Worm gear drive system with deep groove ball bearings. Emergency stop switch.	
Goniometer arrangement	Electrical devices are integrated into Goniometer station. It has 8U spaces for 19" rack devices.	
Alignment laser	Red cross-line laser (5mW), 1 pc	Red cross-line laser (5mW), 2pcs
Height of the device, diameter of rotation	1.4 m, D=1.4 m	1.8m, D=1.8m
Height of optical axis	~1.0 m	~1.4 m
Max total length, width and mass of DUT ²	0.6 m, 0.5 m, 10kg	1.4 m, 0.6m, 20kg
Resolution	<0.01° (B and β axis)	
Reproducibility / Accuracy	<0.1° (B and β axis)	
Turning range, B plane	±90° (Vertical plane / Horizontal measurement axis) *)	
Turning range, β angle	±90° (Horizontal plane / Vertical measurement axis)	
Movement range, Z-direction	None:	0.3 m
Minimum room space (WxHxL)	2.0 m x 2.0 m x 7 m	2.5 m x 2.0 m x 15 m

*) For heavy loads, a counterweight is needed.

Type A GONIOPHOTOMETER SSL AUTO 50.A

MEASUREMENT of ANGULAR LUMINOUS INTENSITY DISTRIBUTION in H,V AXIS COORDINATES of

- ✓ Maritime navigation lights
- ✓ Automotive lights
- ✓ Airport taxiway/runway lights



Goniometer	SSL AUTO 50 (Product code SSL A.50)
Goniometer type	Type A Goniometer according to IES LM-75-01
Gonio driver and controller	3 axis Stepper motor controller with RS-232 / USB interface, Worm gear drive system with deep groove ball bearings. Emergency stop switch.
Goniometer arrangement	Electrical devices are integrated into Goniometer station. It has 4U spaces for 19" rack devices.
Alignment laser	Red cross-line laser
Height, diameter of rotation	1.6 m, D=1.0 m
Height of optical axis	Approximately 1.06 m
Max total size and mass of DUT ²	Diameter 600 mm, 250 mm (from bottom to optical center), 5kg
Resolution	<0.01° (A and α axis)
Reproducibility / Accuracy	<0.1° (A and α axis)
Turning range, A plane ¹⁾	$\pm 90^\circ$
Turning range, α angle ²⁾	$\pm 90^\circ$, effective dead angle in $80^\circ \dots 85^\circ$ depending on the source size
Movement range, Z-direction	300 mm motorized
Minimum room space (WxHxL)	1.7 m x 1.7 m x >6 m

¹⁾ A plane = Vertical plane / Horizontal measurement axis

²⁾ α angle = Horizontal plane / Vertical measurement axis

Type A GONIOPHOTOMETER

SSL AUTO 500 (M)

Goniometer	SSL AUTO 500 (Prodcut code SSL A.500)
Goniometer type	A type
Gonio controller	3 axis Stepper motor controller with RS-232 / USB interface. Emergency stop switch.
Goniometer rack	Devices are integrated into Goniometer station with 7U free space for 19" devices
Alignment laser	Red cross-line laser mounted on the photometer stand
Goniometer dimensions	Height 2.4 m (2.5m for operation), Turning diameter 1.07 m. Mass: 300kg.
Height of optical axis	Approximately 1.4 m
Max length, height and mass of DUT ²	Diameter 1.06 m. Mass: 30kg Height (bottom – center): 0.53 m, Height (center to counterweight): 0.63 m Total fixture height (limited by room height): 1.67m (room height 2.5m)
Resolution	<0.01° (A and α axis)
Reproducibility	<0.1° (A and α axis)
Turning range, A plane	$\pm 180^\circ$ (A plane) $\pm 90^\circ$ (α angle)
Movement range	Z-direction up to turning axis with no sample holder stages: 70 cm, X and Y axis: 30cm
Minimum room space	Width 1.8 m, Height 2.5 m, Length: 1.2m + test distance from the standard requirement

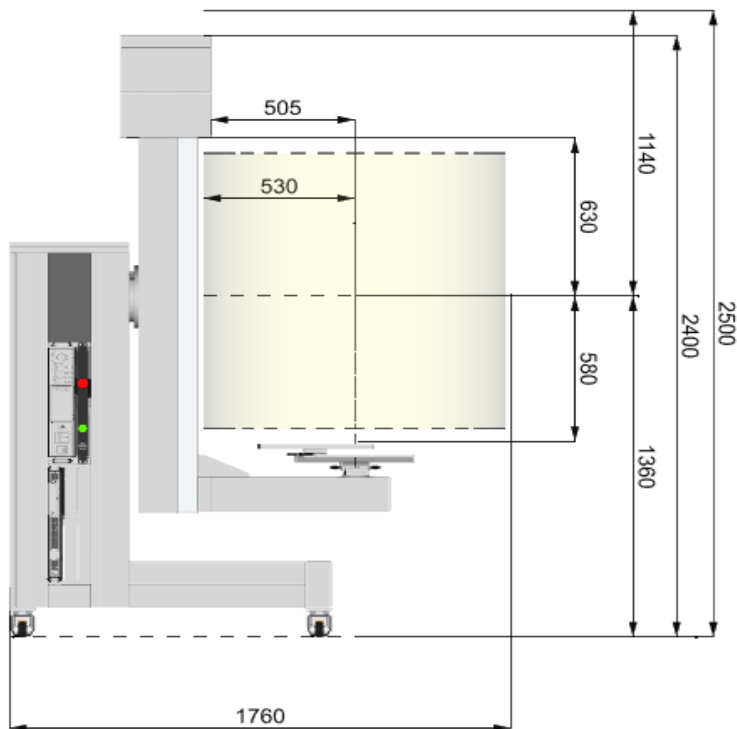

Fig. Dimensions. Light yellow indicates a DUT with the size of 1m height and 1m diameter.

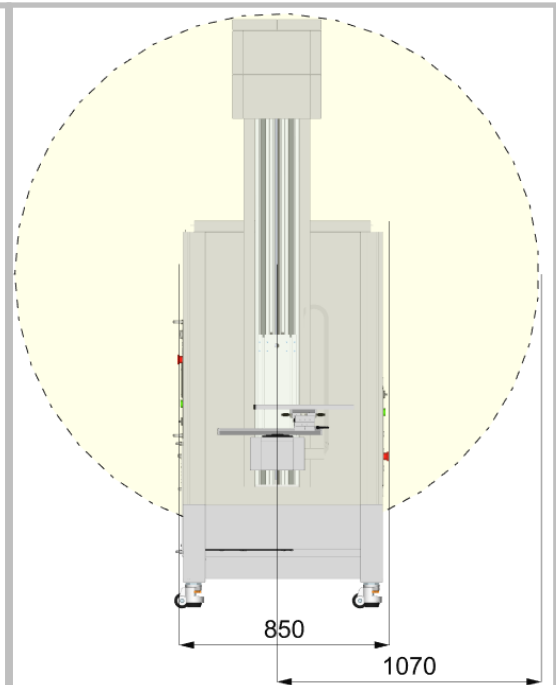
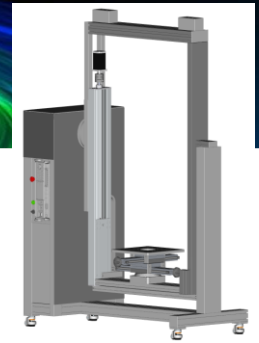

Fig. Depth dimensions. Light yellow indicates a circular area needed for rotation of α axis.

Type A GONIOPHOTOMETER SSL AUTO 1000



- ✓ Maritime navigation lights
- ✓ Automotive lights
- ✓ Railway lights
- ✓ Traffic lights (VMS)
- ✓ Airport taxiway/runway lights

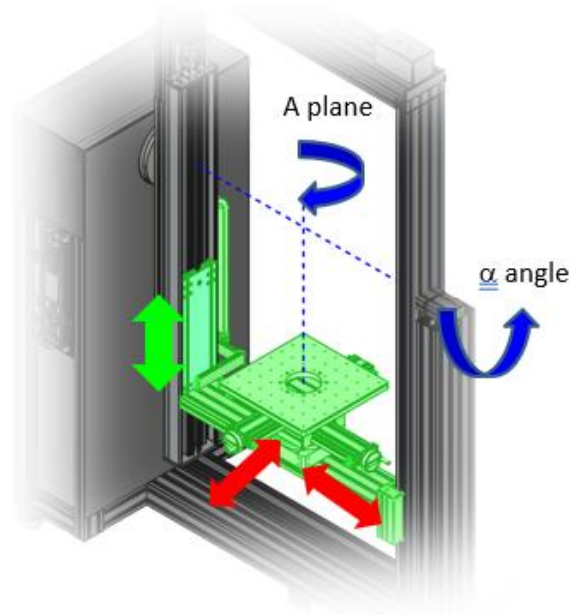

Fig. 3-axis Motorized Control:

- α horizontal axis for vertical angles
- A plane vertical axis for horizontal (V) angles
- Z linear vertical axis for positioning to the turning axis of A plane

Optional 2-axis Manual control:

- X and Y linear horizontal axes for positioning to the turning axis of α axis

Goniometer	SSL AUTO 1000 (Product code SSL A.1000)
Goniometer type	A type
Gonio driver and controller	3 axis Stepper motor controller with RS-232 / USB interface, Worm gear drive system with deep groove ball and crossed roller bearings. Emergency stop switch.
Goniometer arrangement	Electrical devices are integrated into Goniometer station. It has 8U spaces for 19" rack devices.
Alignment laser	Red cross-line laser
Height, diameter of rotation	2.5 m, D=1.2 m
Height of optical axis	Approximately 1.5 m
Max total length, height and mass of DUT ²	1 m, 1 m (0.85m with XY linear axis), 50kg
Resolution	<0.01° (A and α axis)
Reproducibility / Accuracy	<0.1° (A and α axis)
Turning range, α angle ¹⁾	±30° at maximum load, ±100° at adjusted load with counterweight
Turning range, A plane ²⁾	±180°
Movement range	Z-direction (Motorized axis): 1 m, Optional X and Y axis: 0.3 m.
Minimum room space (WxHxL)	2 m x 2.5 m x (12 – 37) m

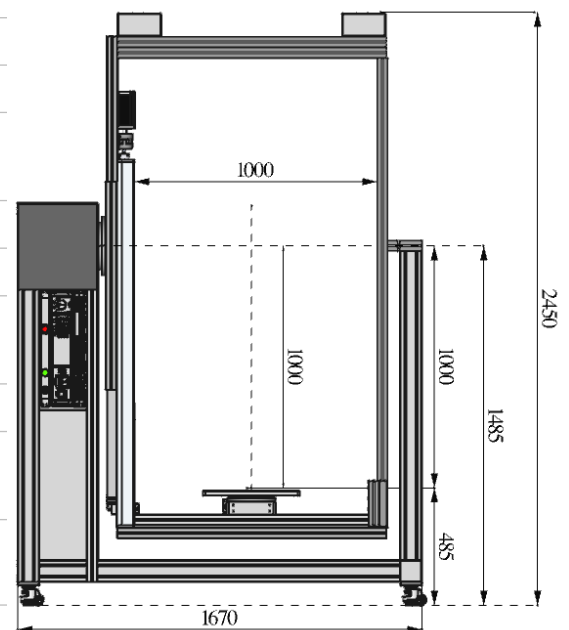

¹⁾ A plane = Horizontal angle / Vertical (moving) axis

²⁾ α angle = Vertical angle / Horizontal (fixed) axis

Gonio System Delivery

OPTION 1: Standard package

Description: The goniometer station and accessories are tightly packed into a relatively small transport wooden box. The laboratory room is prepared by black before the gonio delivery.

Advantages:

- Fits normally through the standard doors

Disadvantages:

- More unpacking and assembly work.
- Roof, floor and walls of Gonio Laboratory room needs to be covered by low reflectance diffuse black material.
- Laboratory lighting needs to be constructed.

OPTION 2. SSL Gonio-nest (Figures below)

Description: The goniometer station and accessories are transported inside SSL Gonio-nest. When setuping the SSL Gonio-nest, its front wall is removed and the additional side walls and carpet are installed around the dark chamber.

Advantages:

- No need for separate transportation box and additional unpacking work.
- No need for black laboratory room or building illumination to the laboratory room
- Automatic switch on/off of ambient lighting during measurements

Disadvantages:

- Door size needs to be larger.

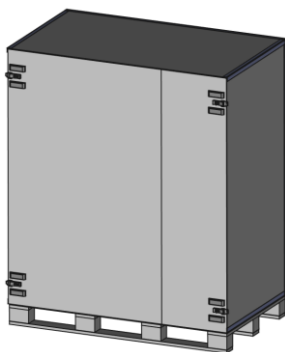

SSL Goniometers

Ordering information

Goniometers

LAMP 30	2-axis Goniometer station (C, γ). GPM-sw-base, SLET, stand-1, Alignment laser
LAMP 200	
LEDI 70	2-axis Goniometer station (C, γ . GPM-sw-base, SLET, stand-1, Alignment laser, RACK-1
UNI 170	
LUMI 90	2-axis Goniometer station (C, γ), GPM-sw-full, SLET, stand-2, Alignment laser
LUMI 180.2	
LUMI 120	3-axis Goniometer station (C, γ), motorized vertical arm, GPM-sw-full, SLET, Stand-2,
LUMI 180.3	Alignment laser
LUMI 180 H	
LUMI 180 BPC	4-axis Goniometer station (C, γ), motorized vertical arm, BPC correction integration, GPM-
LUMI 180 H BPC	sw-full, SLET, stand-2, Alignment laser
DECO 27	a floor mounted C type goniometer with vertical optical axis, SLET, GPM-full-sw
AUTO 100	2-axis Goniometer station (B, β), GPM-sw, SLET, stand-1, Alignment laser
AUTO 140	
AUTO 50.A	3-axis Goniometer station (A plane, α , Z), GPM-sw, SLET, Al-profile stand, Alignment
AUTO 500	laser, lv-spec sw
AUTO 1000	

Sample holders

SH-lin-2	2-handed linear sample holder with trapezoidal screw for LUMI 120 / LUMI 180
SH-lin-3	2-handed linear sample holder with trapezoidal screw for LUMI 90 / LUMI 130 L
SH-linear__xxx	Sample holder of linear LUT (xxx specified by the gonio model, e.g. LUMI 120, xxx=120): two attaching mechanisms: (1) by squeezing the LUT with four angle brackets (2) by screwing the LUT using square nuts (M4/M6/M8) in the grooves (angle brackets removed)
SH-park	Sample holder of park lights: Mounting by squeezing a park light from its edges, max. \varnothing 70 cm, a top of the park light can be located into center hole diameter 12 cm
SH-panel	Sample holder of panel lights and down lights : Mounting by squeezing a LED panel from its edges, compatible for different sizes LED panels with thicknesses of >7.5 mm
SH-street 20	Sample holder of street luminaires with pole mounting system: 60mm tube, fixation by two screws in radial orientation, max. distance between mounting hole and the roof of the LUT 20cm
SH-down	Sample holder of recessed down lights:A Long angle brackets for a spring fixation of a down light, max. \varnothing 40cm, thickness 30 cm
SH-flood	Sample holder of floodlights, high bay lights, etc., solid mounting of heavy luminaires, asymmetric installation. Two alternatives attaching mechanisms: Horizontal/ vertical mounting

SSL Goniometers - Options

Ordering information

Options (not complete list, ask if you anything else)

SSL LUMI.B-xxx	B type goniometer option to be connected onto a goniometer station. Including mechanical adapters and sw add-on. xxx specified by the base gonio model.
SSL lv-Spec-sw	Luminous intensity specification editor for candela sw tool add-on of GPM sw. - User can create the candela specifications for standards such as ECE, FVMSS108 to meet different type of specifications like Zone, Line, Group of Test points, Single test points...
SSL BPC-B	Burning position corrector setup of B type gonio including L-50 photometer (Bluetooth communication) and a related software tool
SSL-BPC-c	Setup for burning position corrector including L-50 photometer (Bluetooth communication) and a related software tool
SSL IMG-2	Add-on Imaging setup for goniometer LUMI: Typical installation distance 3m at the secondary AI profile stand. 2.3Mpix USB3.0 camera & 25mm lens. Camera sw add-on.
SSL-black	Special low reflectance black material for a back wall and floor of gonio laboratory room
SSL Gonio- nest_xxx	Dark chamber for easy installation of the goniophotometer. It is also used for goniophotometer transportation box. "xxx" specifies the gonio model.
SSL-PC	Measurement computer with needed communication cards and installation work (drivers and software)
SSL rack-2	Mobile device rack and computer table. Space for 8U 19" rack device

Training

SSL-onsite- service	Goniometer system first installation and basic training including example measurements on customer site (1-3 days)
SSL-online- service	Goniometer system remote installation and training through Teams/Teamviewer (x hours)

SSL Goniophotometer - Accessories

T-3K.BT 3-channel K-type Thermometer



- ✓ Ambient temperature
- ✓ LED board temperature
- ✓ Tc point temperature
- ✓ Standards require ambient temperature to be 25.0°C at tolerance of $\pm 1.2^\circ\text{C}$ (CIE S025) or of 1.0°C (LM-79)

TEC-40W, Thermo-electric cooler

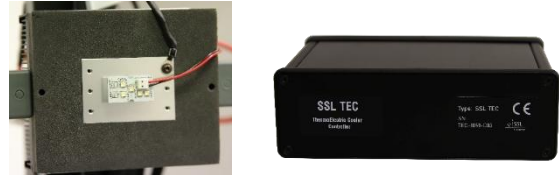

Temperature control of LED light source in Goniophotometer and integrating sphere tests

- Case 1: Reference light source with thermally stabilized output
- Case 2: Characterization of light source as a function of temperature

DC-xxx, Programmable DC power supply integration

- ✓ DC-sw sweep for automatic measurement of luminous output as a function of drive current/voltage
- ✓ Banana connector panel with 4-wire electrical connection for reliable and accurate electrical power measurements
- ✓ Compatible e.g. with TDK and GW Instek brand power supplies.

SSL ACP-DCM, Programmable AC supplying and DC metering system **NEW**

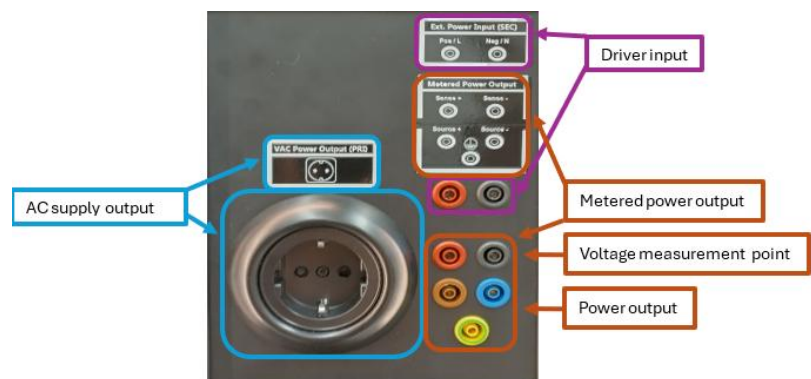

- ✓ Stable AC power supply & Automatic switching
- ✓ Multiple operation modes e.g. solar battery lamps / DC lamps / AC driver lamps
- ✓ Measurements parameters
 - AC input power, V, I, PF
 - DC output power, V, I
 - LED Driver efficiency

Contact Information



SSL Resource Oy
Myllyojankatu 2A
FI-24100 Salo, FINLAND

+358 (0)44 360 8199
sales@sslresource.com
www.sslresource.com

